

Shanghai Mitsubishi Elevator Co., Ltd.

Address: No. 811 Jiangchuan Road. Minhang, Shanghai, China

Tel : +86-21-24083030/64303030

Fax : +86-21-24083088

Post: 200245

Overseas Business

Tel : +86-21-24083482

Fax : +86-21-24083488

e-mail : overseasbiz@smec-cn.com



www.smec-cn.com



Specifications subject to change without notice
Printed in Oct. 2013 (GB-C)



Series K

Escalator

A Perfect Integration:
Advanced Technologies and Energy Saving
Art and Wisdom

Series K | Escalator

Excellent Quality Supported by Technological Advantages

Shanghai Mitsubishi Elevator Co. Ltd. is privileged with world-class manufacturing equipments and highly-competent staff, and we have the world's leading manufacturing system and rich experience of practices. Our humanistic products are based on long-term leading technological strength and the accurate understanding of enjoyment. Shanghai Mitsubishi Elevator Co. Ltd. is glad to present the Series K escalator, which is stable, efficient, and energy saving, and provides users a safer and more comfortable experience. The Series K are applicable to a wide range of conditions, include but not limited to shopping malls, office buildings, hotels, and other business areas.

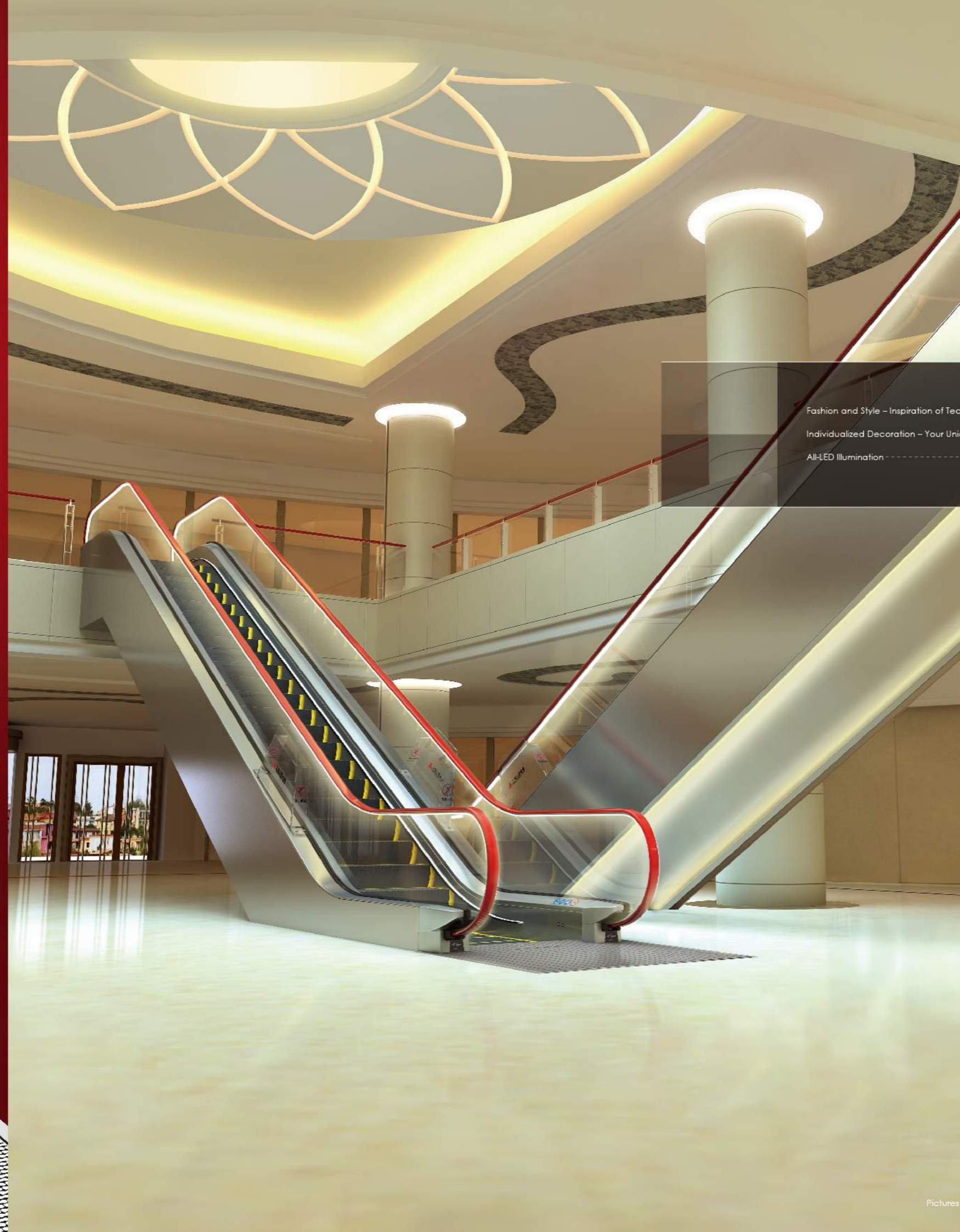
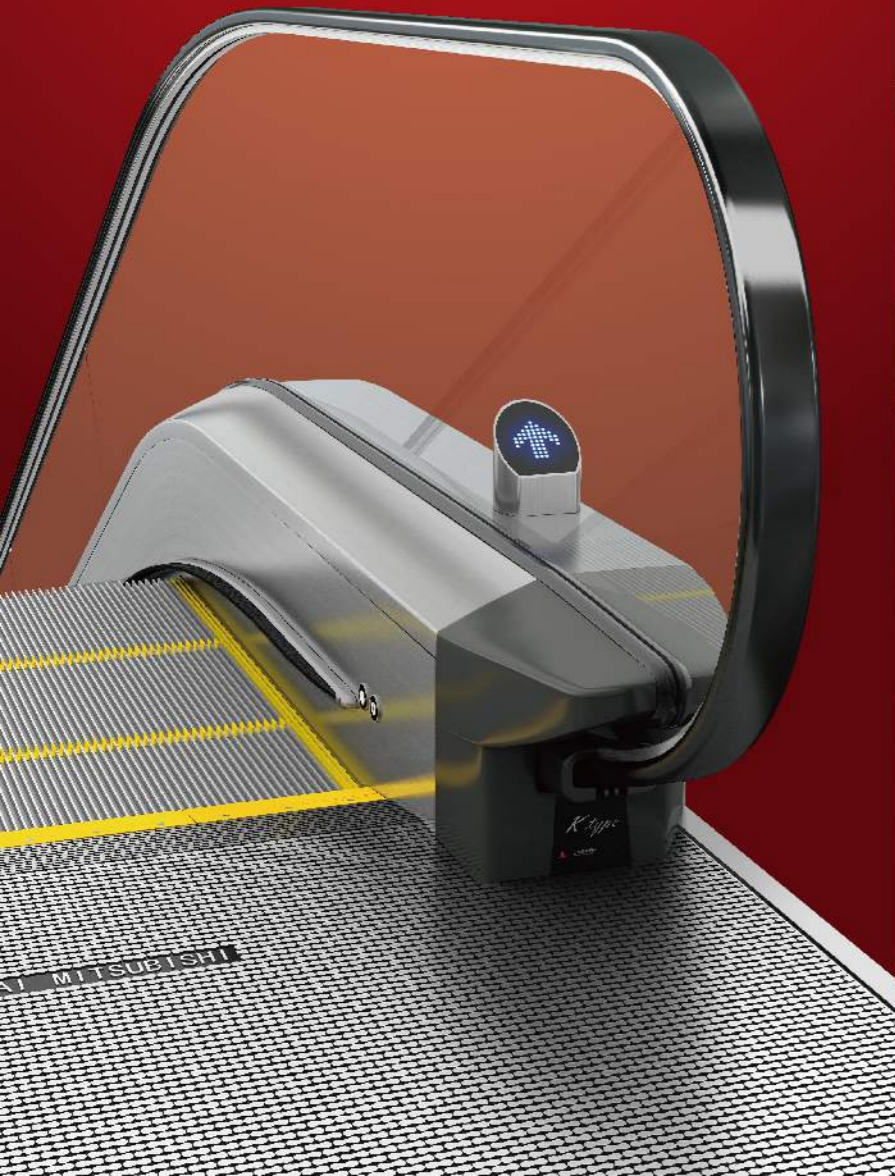

A Perfect Integration
Advanced Technologies and Energy Saving
Art and Wisdom
The Escalator – the Series K

| | |
|---|------|
| Energy Efficient, Space Saving | P.3 |
| The Frequency Conversion Technology – a Mitsubishi Heritage | P.6 |
| Security System - Humanistic and Reliable | P.8 |
| Exquisite Processing, Excellent Quality | P.10 |

| | |
|---|------|
| Fashion and Style – Inspiration of Technologies from Life | P.11 |
| Individualized Decoration – Your Unique Decoration Solution | P.14 |
| All-LED Illumination | P.18 |

| | |
|--------------|------|
| Feature List | P.19 |
|--------------|------|

| | |
|--------------------|------|
| Civil Work Drawing | P.21 |
| Civil Work Data | P.22 |

| | |
|----------------------|------|
| Basic Specifications | P.24 |
|----------------------|------|

General

Design

Functions

Civil

Specifications

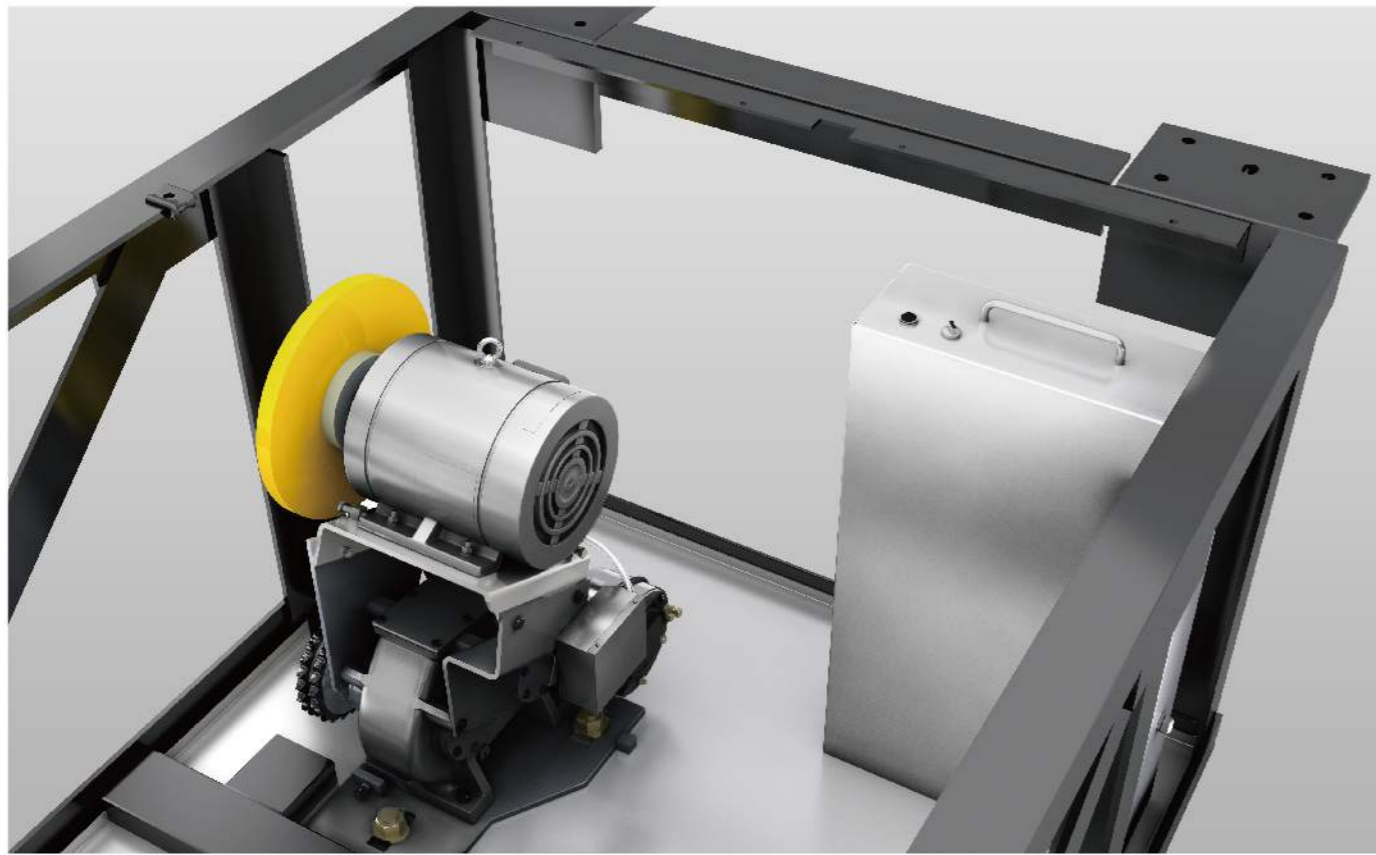

Energy Efficient Space Saving

Helical Gear Reducer

Comparison between the efficiency of helical gear reducer and that of worm gear reducer.

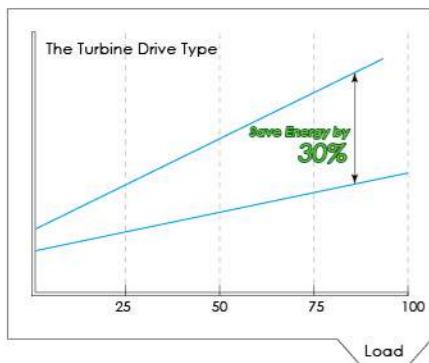

The high-precision helical reducer is more efficient than traditional turbine worm reducer, and ensures outstanding energy efficiency.

High-precision Helical Gear



The helical gear is more efficient in transmission while occupies less space and causes no pollution. It has a big transitional torque, and starts smoothly, thus it could be applied to high-speed heavy load when closely attached to the center distance.

Refined Design, and Space Saving

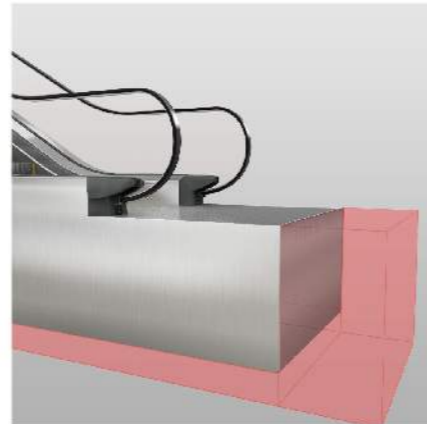

The staircase system is reasonably designed with a short length of span, which helps to reduce the civil work sizes by large and saves space.

Frequency Conversion – Detect the Passenger Flow in Varied Ways

Sketch map of the frequency conversion operations

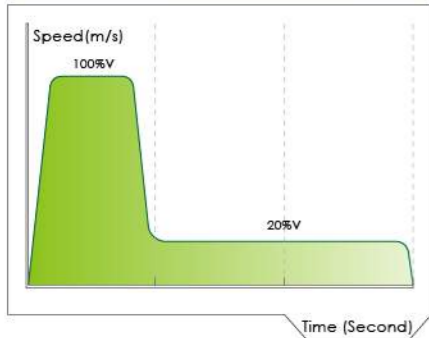

The integrated frequency conversion approach detects the passenger flow in varied ways and forms a detection area, so as to support the escalator to operate or stand by as necessary, and save energy from avoiding idling.

Post Type Passenger Detection Device

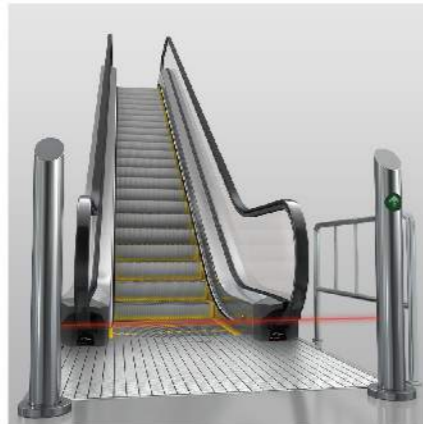

The device is installed in the inner side of the stand post in the upper and lower inlets and outlets, and forms a horizontal area of induction detection, which could adjust the speed of the escalator according to the amount of passengers loaded and save energy.

Built-in Passenger Detection Device



The device is built into the inner side and the front of the newel at the upper and lower inlets and outlets, and forms a large area of induction detection, which could adjust the speed of the escalator according to the amount of passengers loaded and save energy.



**Exquisite Processing
Excellent Quality**

Disc Brake

The disc brakes adopted make the structure compact and the braking smooth.

Stainless Steel Front Plate

The front plate is made of stainless steel with anti-skid pattern, which is both artistic and durable. It reduces the risk of slipping.

Truss Built with Angle Steel

We stick to steel angles which make the truss better in rust protection and more durable. If we compare steel angles with rectangular steel pipes in terms of the same section, the deflection of steel angles are smaller than that of rectangular steel pipes, and thus the steel angles are less likely to deform.

Large Special Jig

Assembled with large special jig, accuracy and quality of the staircase system are ensured, and extra workload from re-assembly and adjustment is avoided.

Quiet Turning and Meshing

The drive chain wheel is directly meshed with the step roller made of high polymer wearable resin, which avoids rigid shock between metal of the chain wheel and the step shaft. The turning and meshing of steps are quiet and smooth.

Integral Design

The upper and lower reversions and the staircase guide rails are designed as one piece, so as to avoid movement of the staircase, ensure seamless linkage between the guide rail and the reversion at the turning section, and reduce the vibration of steps in operations.

Automatic Oiler and Oil Level Warning

The automatic fuel feeding device is a standard component of the escalator, and it could help to reduce the labor of manual maintenance needed and keep the escalator in good condition. The oil level warning system is also a standard component. It could avoid any operation of the escalator without oil, and protect the life span of the step chain transmission.

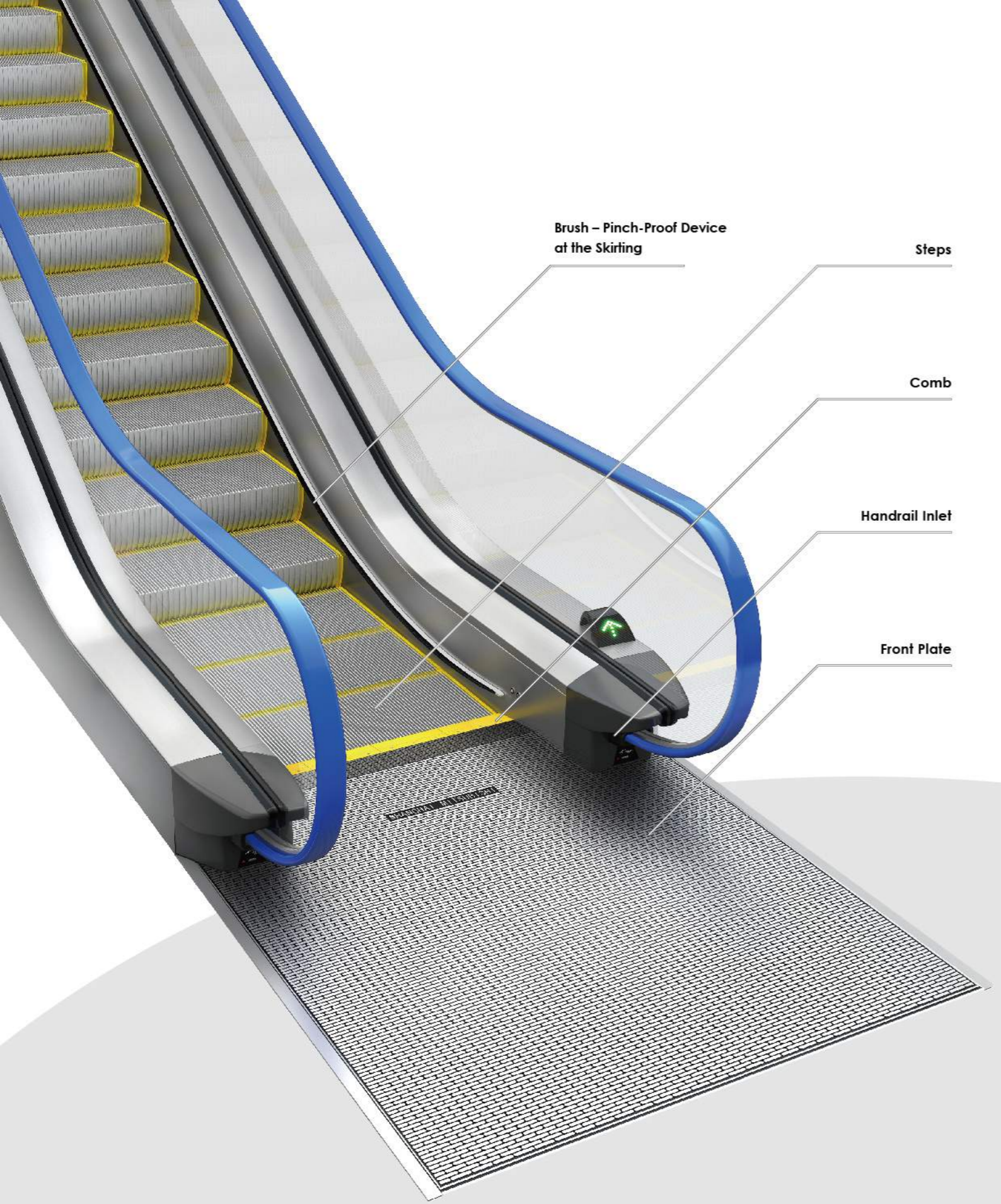

Handrail Inlet

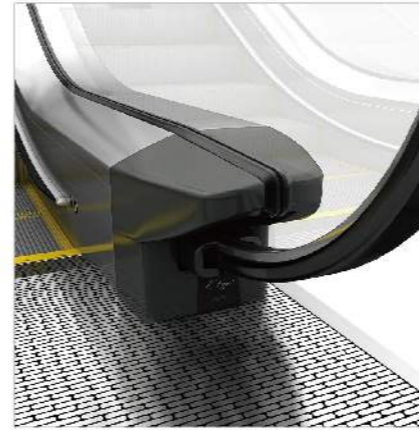

As a Mitsubishi tradition, the handrail inlet is designed to be hidden, which reduces the risk of pinch by margin. Long and soft protection covers are applied to the handrail inlet, which embodies our strategy of multiple layers of protection.

Brush - Pinch-Proof Device at the Skirting

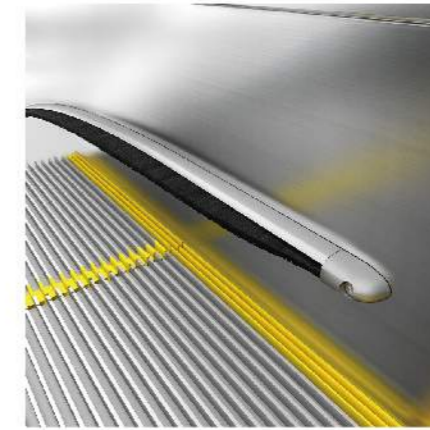

The brush ensures that the passengers will not stand too close to the edge of steps or pinch their feet by accidentally placing their feet between the steps and the skirting panels.

The Series K escalator is equipped with several safety devices. Beside all the safety devices required by the GB16899-2011 codes, other safety devices can also be installed as per customer requirements.

Security System - Humanistic and Reliable

Anti-creeping Device (Optional)



If there is a risk of passengers falling from the escalator, anti-creeping device could be installed onto the external cover plate so that nobody could climb onto the handrail.

Entry Prevention Device

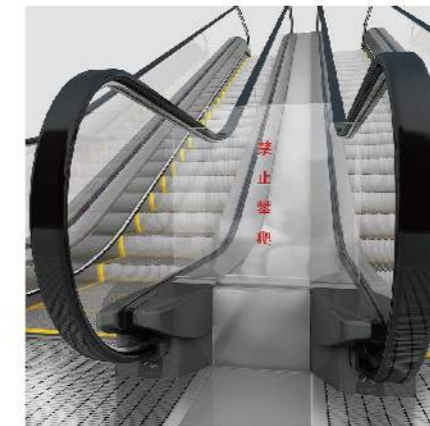

If there are risks of entry and/or falling after entry, please use the entry prevention device. (To be installed by the customers.)

Anti-skid Device



If there is the risk of falling of personnel or objects, please use the anti-skid device. (To be installed by the customers.)

Comb

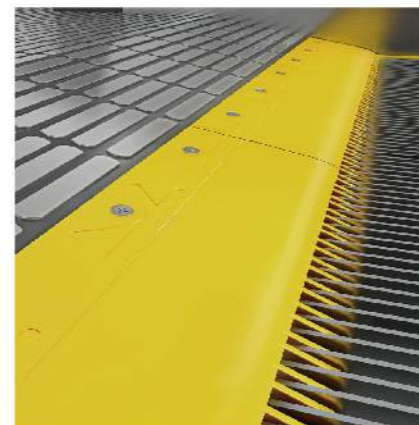

Angled design allows buffer between the decoration panels and the steps, so as to avoid pinching of passengers' fingers, feet, or other foreign objects between moving steps and the floor lab.

Steps

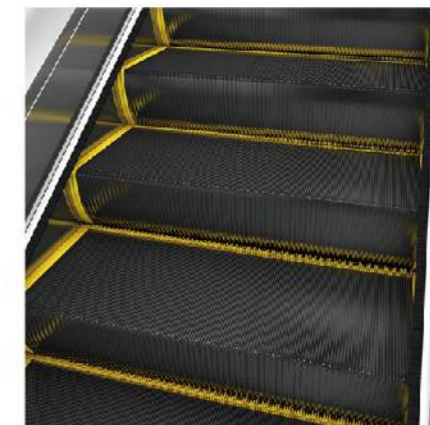

Stainless steel steps with anti-slip grooves could be marked with bright yellow boundary lines, to remind customers of potential risks.

Front Plate

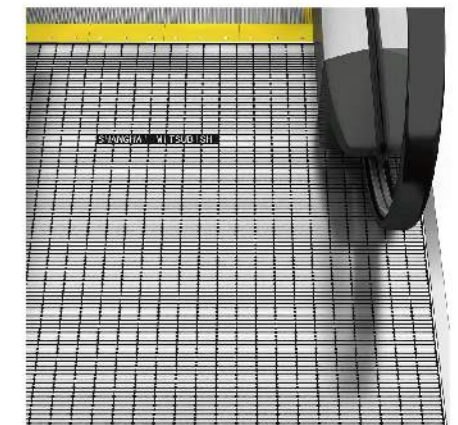

Front plate with notches and grooves prevent slipping of passengers.

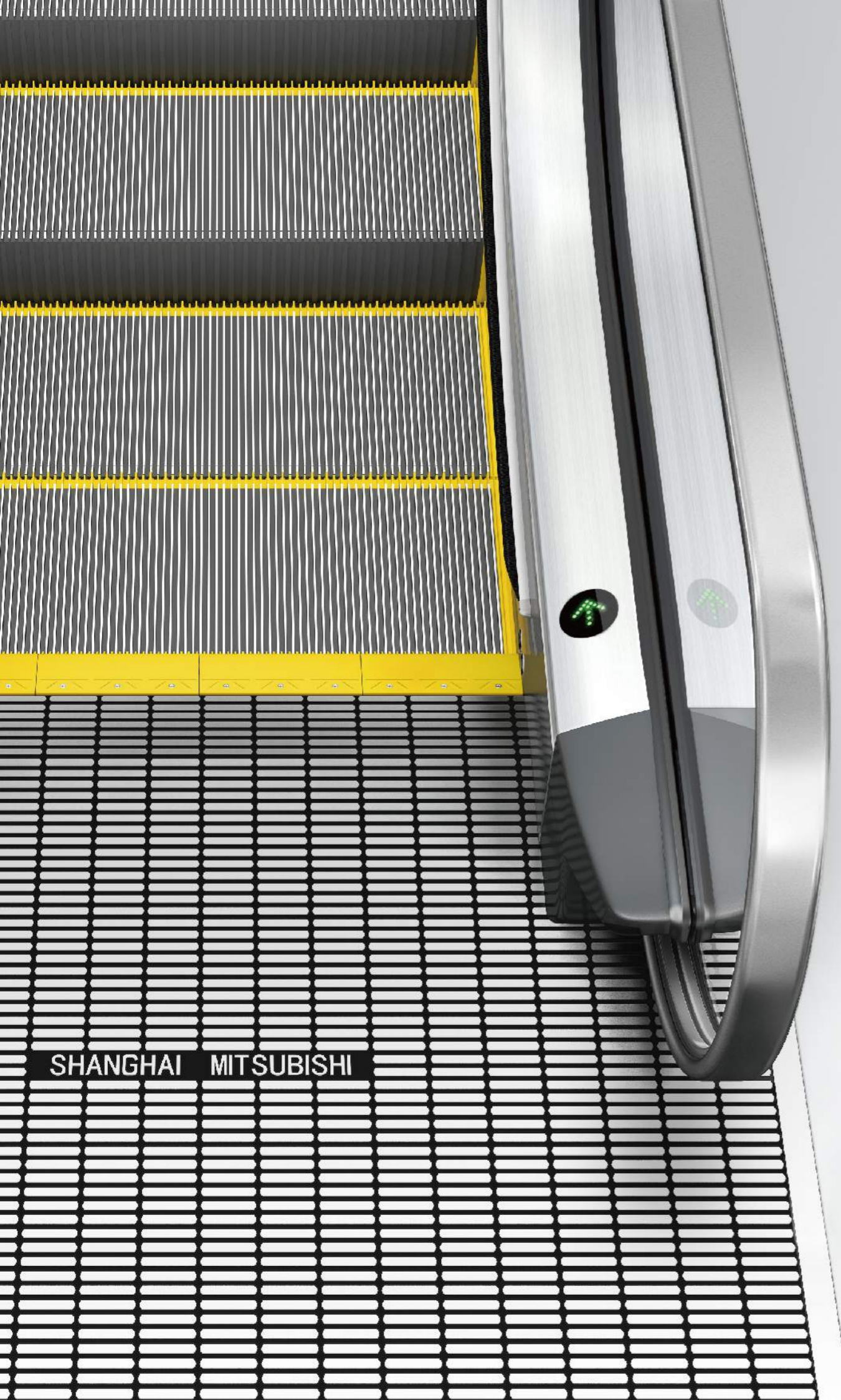

SHANGHAI MITSUBISHI

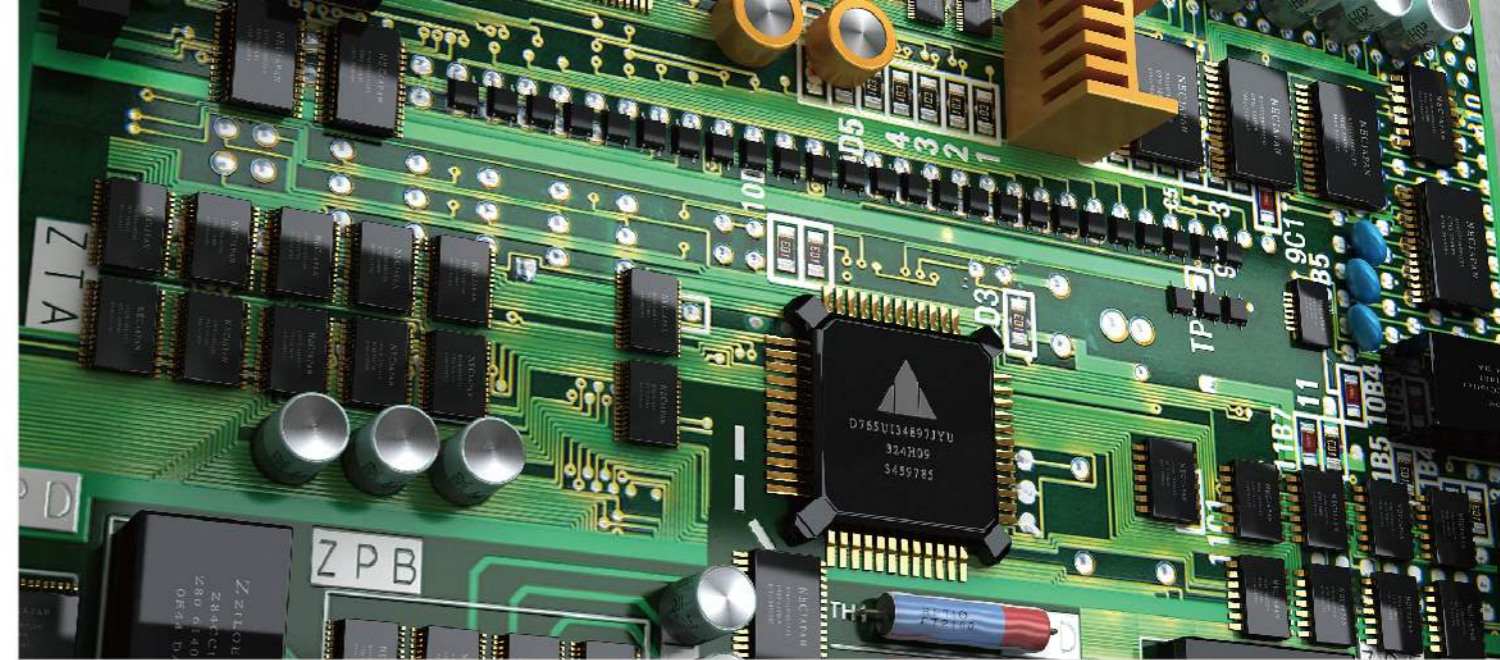

The Frequency Conversion Technology – a Mitsubishi Heritage

Special Frequency Converter

The Mitsubishi-developed special frequency converter is designed in a modular manner. It is small, and convenient to repair and replace. With the advanced technologies of power phase tracking and "quasi-zero phase difference" switching, the escalator could be switched smoothly from variable frequency to power frequency.

Bypass Frequency Conversion

When the escalator operates with the nominal speed, cut out the frequency converter automatically and shift to the power grid which could increase the lifespan of the converter significantly. In case of any unrecoverable error with the converter, switch to the power frequency grid manually, and the operations of the escalator will not be blocked. In case of no load, the escalator will automatically switch to low velocity standby or stop standby. Regenerative power from descending would be fed into the grid, which is energy saving and environment friendly.

Functional Safety Device

Dual-channel redundancy inspection ensures that the safety devices are reliable and effective, with a failure rate lower than one in a million. With all-rounded power monitoring and protection measures, any over-voltage or under-voltage error would lead the system into the safety model.



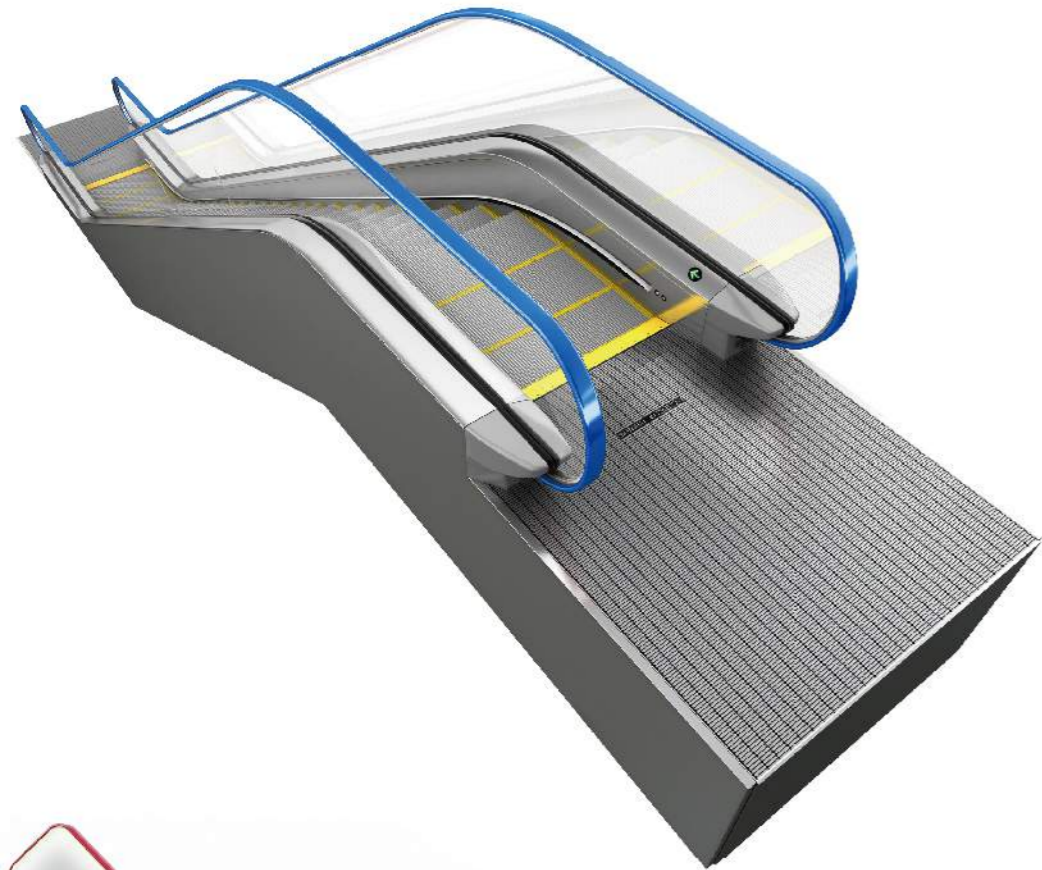

Type of the Balustrade
KS-SB / KS-SBF

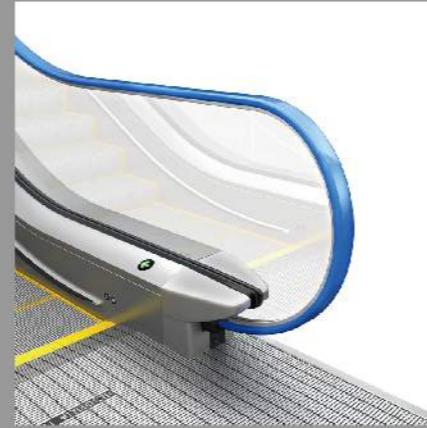

Instructions to the Components Indicated in the Figure

- Internal Side Plate**
Transparent Rectangle Glass
- Steps**
Aluminum Alloy with Yellow Resin Strips on Three Sides
(With other options available), Silver Grey Coating (Color No. ZY-028)
- Handrail**
Bright Blue PU (Color No. NT-Blue) (With other options available)
- Internal and External Cover Plates**
Hairline Stainless Steel (With other options available)
- Handrail Inlet**
ZHE-02A Silver Grey Aluminum Alloy, (Color No. ZY-028)
(With other options available)
- Operation Indicator**
ZIN-02 (With other options available)
- Skirt Panel**
Hairline Stainless Steel (With other options available)
- Front Plate**
ZCY-F01P Stainless Steel with Anti-skid Grooves
(With other options available), and Inside the Groove be Painted Black
(Color No. ZDY-027)

Type of the Balustrade
KS-LB / KS-LBF

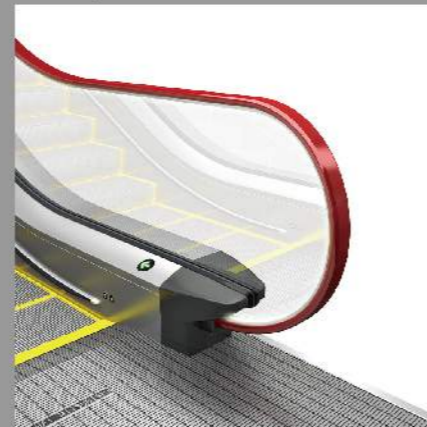

Instructions to the Components Indicated in the Figure

- Internal Side Plate**
Transparent Rectangle Glass
- Steps**
Aluminum Alloy with Yellow Resin Strips on Three Sides
(With other options available), Silver Grey Coating (Color No. ZY-028)
- Handrail**
Bright Red PU (Color No. NT-Red) (With other options available)
- Internal and External Cover Plates**
Hairline Stainless Steel (With other options available)
- Handrail Inlet**
ZHE-02A Black Grey Aluminum Alloy, (Color No. ZY-029)
(With other options available)
- Operation Indicator**
ZIN-02 (With other options available)
- Skirt Panel**
Hairline Stainless Steel (With other options available)
- Front Plate**
ZCY-F01P Stainless Steel with Anti-skid Grooves
(With other options available), and Inside the Groove be Painted Black
(Color No. ZDY-027)
- Handrail Illumination**
Milk white LED (With other colors available)

The Series-K escalators are simple and smooth in appearance, with first class quality. There are multiple styles to suit with different decorations. There are also different designs of the handrail inlet, which are both stylish and safe.

There are options of fashionable colors for EHC PU handrails and glass, textures for skirt panels and internal and external cover plates, and decoration patterns for the front plate, so as to suit with different environments.

Stainless steel steps and aluminium alloy steps are available, while there are different colors and patterns with or without yellow boundary strips for various situations.

Different LED illumination solutions are also prepared to satisfy customer needs, including illumination below steps, below handrails, and at the skirting.

Fashion and Style – Inspiration of Technologies from Life



Form of the Balustrade
KP-B / KP-BF



Instructions to the Components Indicated in the Figure

- Internal Side Plate**
Rectangle Hairline Stainless Steel
- Steps**
Aluminum Alloy with Yellow Resin Strips on Three Sides
(With other options available), Silver Grey Coating (Color No. ZY-028)
- Handrail**
Black PU (Color No. NT-Black) (With other options available)
- Internal and External Cover Plates**
Hairline Stainless Steel (With other options available)
- Handrail Inlet**
ZHE-02A Black Grey Aluminum Alloy, (Color No. ZY-029)
(With other options available)
- Operation Indicator**
At the Handrail Corner Balustrade
- Skirt Panel**
Hairline Stainless Steel (With other options available)
- Front Plate**
ZCY-F01P Stainless Steel with Anti-skid Grooves
(With other options available), and Inside the Groove be Painted Black
(Color No. ZDY-027)



Internal and External Cover Plates

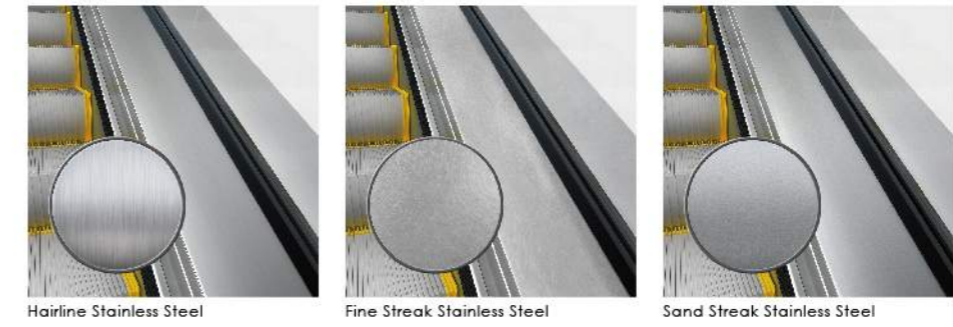

More options for individualized and even more valuable escalators.

Individualized Decoration – Your Unique Decoration Solution

Handrail

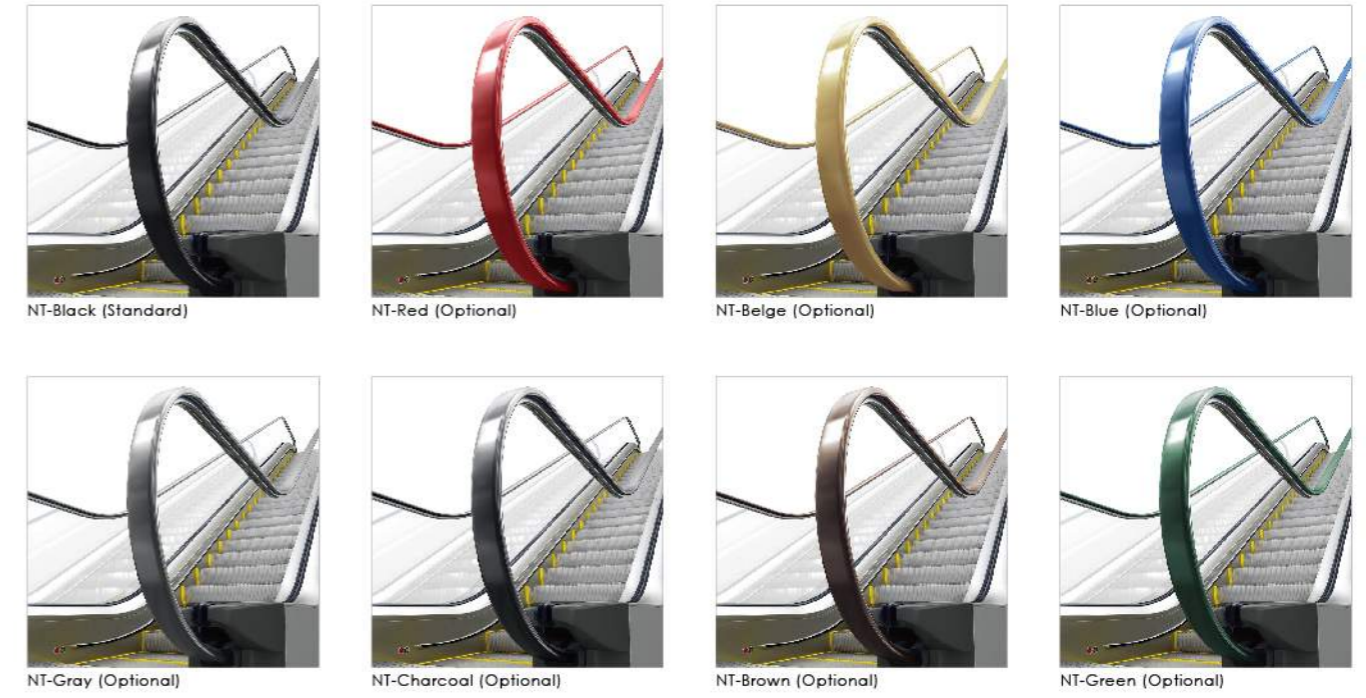

Skirt Panel



Comb

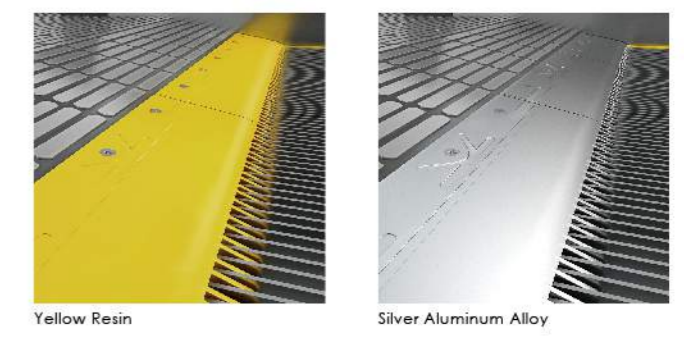

* The specifications selected may cause delay of the lead time. Please contact the Shanghai Mitsubishi Elevator Co. Ltd. to confirm.

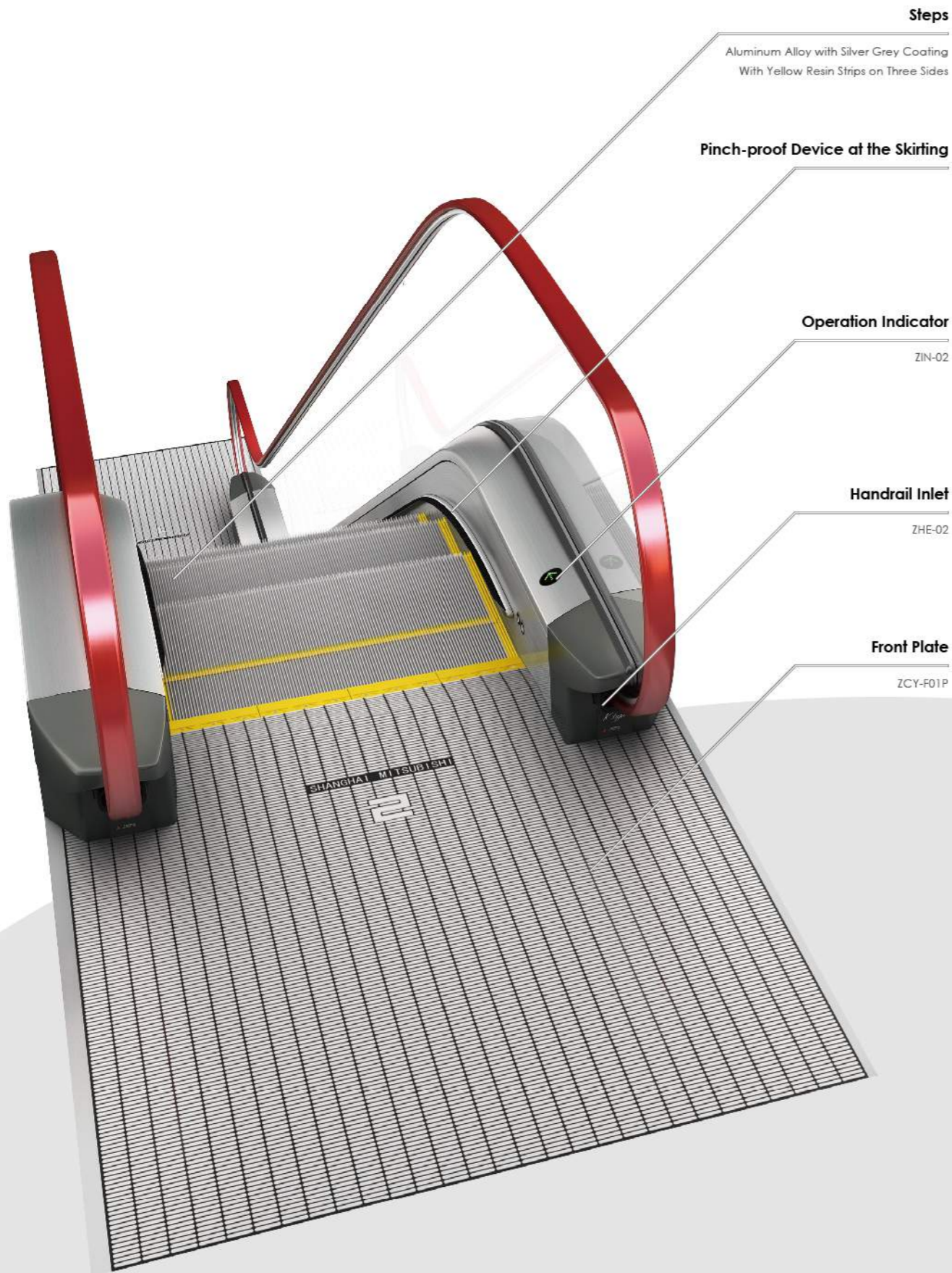

Pinch-proof Device at the Skirting

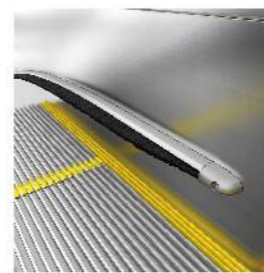

Silver Color Holder with Black Brush

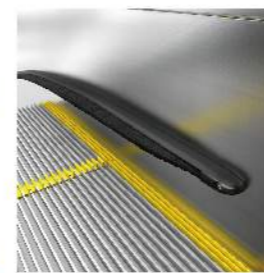

Black Holder with Black Brush

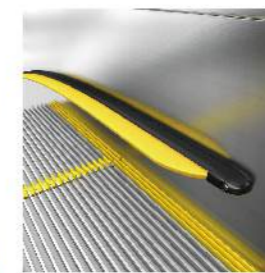

Black Holder with Yellow Cohesive Tape

Operation Indicator

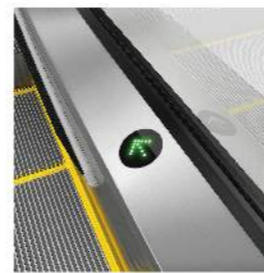

ZIN-02

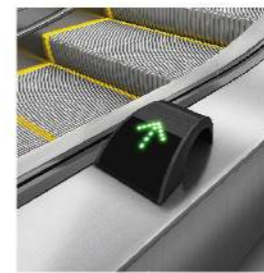

ZIN-01, Only for indoor

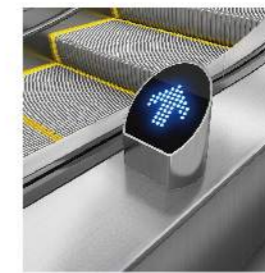

ZIN-03



Operations indicator at the handrail newel balustrade (Only for KP-B/KP-BF)

Handrail Inlet

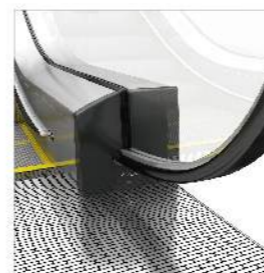

ZHE-01
Black Grey Resin(Color No.: ZY-029)

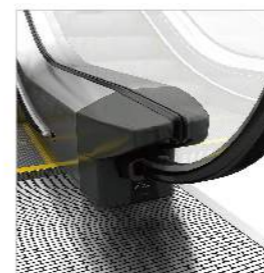

ZHE-02
Black Grey Resin(Color No.: ZY-029)
(Only for KS-SB/KS-SBF and KS-LB/KS-LBF)
(Only for indoor)

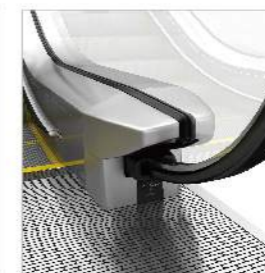

ZHE-02A
Silver Grey Aluminum Alloy
(Color No.: ZY-028)
(Only for KS-SB/KS-SBF and KS-LB/KS-LBF)

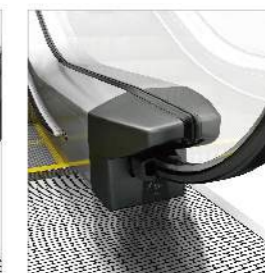

ZHE-02A
Black Grey Resin(Color No.: ZY-029)
(Only for KS-SB/KS-SBF and KS-LB/KS-LBF)

Front Plate

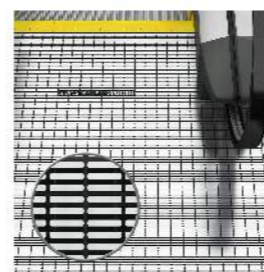

ZCY-F01P
Stainless steel with anti-skid grooves and black coating inside.
(color No. ZDY-027)

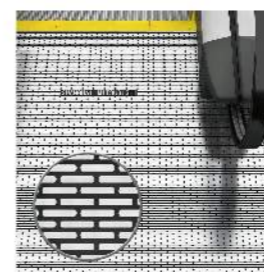

ZCY-F02P
Stainless steel with anti-skid grooves and black coating inside.
(color No. ZDY-027)

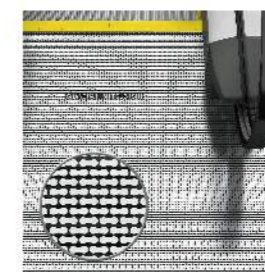

ZCY-F03P
Stainless steel with anti-skid grooves and black coating inside.
(color No. ZDY-027)

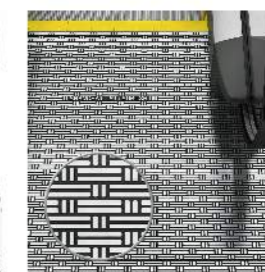

ZCY-F04P
Stainless steel with anti-skid grooves and black coating inside.
(color No. ZDY-027)

Steps

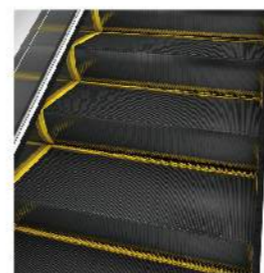

Stainless Steel Steps
With yellow resin strips on three sides, black coating (Color No. ZDFY-027)



All-rounded Aluminum Alloy Steps
No yellow resin strip, black grey coating (Color No. ZDFY-029)



All-rounded Aluminum Alloy Steps
No yellow resin strip, silver grey coating (Color No. ZDFY-028)

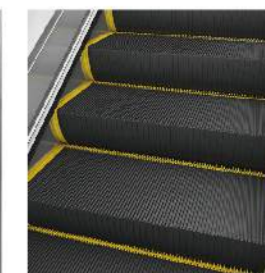

Aluminum Alloy Steps
With yellow resin strips on three sides, black grey coating (Color No. ZDFY-029)

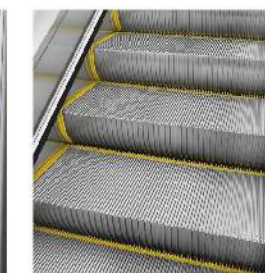

Aluminum Alloy Steps
With yellow resin strips on three sides, silver grey coating (Color No. ZDFY-028)

* The specifications selected may cause delay of the lead time. Please contact the Shanghai Mitsubishi Elevator Co., Ltd. to confirm.



Handrail Illumination

White LED

Skirting Illumination

Successive White LED

Comb Illumination

White LED

The Series K escalator uses LED illumination to all systems, including handrail, skirting, comb, and below steps. The all-LED solution improves the environmental conditions, saves energy, and is safe and reliable. The light below stairs is green, and colors can be selected for all other illumination systems.

All-LED Illumination

Handrail Illumination

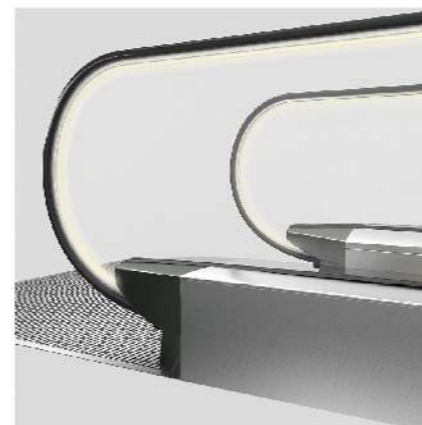

Only for KS-LB/KS-LBF, and colors can be selected

Skirting Illumination



Successive type, and colors can be selected



Dot type, white

Comb Illumination



Colors can be selected

Below Steps Illumination

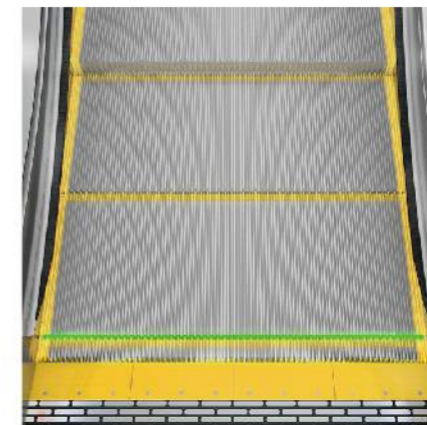

Green

Illumination Colors

Standard Options:



Non-standard Options:

(Please contact Shanghai Mitsubishi Elevator Co. Ltd.)



*The specifications selected may cause delay of the lead time. Please contact the Shanghai Mitsubishi Elevator Co. Ltd. to confirm.

| Feature | Description | Code | Non-frequency Conversion | Frequency Conversion |
|---|---|-----------------------|--------------------------|----------------------|
| Control and Security Features | | | | |
| 01 Phase Dislocation/Phase Loss Protection | In case of phase dislocation or phase loss of the input power supply, cut the main circuit and control the circuit to stop the escalator. | 3E | Ⓢ | Ⓢ |
| 02 Non-manipulated Reversion Protection | In case of accidental reversion of the escalator, the device will cut down the power supply to the main drive motor and the brake. | ARP | Ⓢ | Ⓢ |
| 03 Auxiliary Brake | When the escalator reaches 1.4 times of the rated speed or is not operating in the required direction, the auxiliary brake stops the escalator. | AUX-BK ⁻¹ | Ⓢ | Ⓢ |
| 03 Auxiliary Brake | When the escalator reaches 1.4 times of the rated speed or is not operating in the required director, the auxiliary brake stops the escalator. | AUX-BK ⁻² | Ⓢ | Ⓢ |
| 04 Detection of Service Brake Actions | Stop the escalator when the service brake cannot release or brake normally. | BLR | Ⓢ | Ⓢ |
| 05 Service Brake | The service brake takes action to stop the escalator, and keep it stopped. | BRK | Ⓢ | Ⓢ |
| 06 Bended Guide rail Safety Device | When any object gets pinched between the pallets of two steps and causes abnormality of the operation, stop the escalator. | CRS | Ⓢ | Ⓢ |
| 07 Comb Plate Safety Device | When any foreign object falls between the pallets and the comb plate, stop the escalator. | CSS | Ⓢ | Ⓢ |
| 08 Detection of Contactor Action | In case of any abnormality with the contactor, stop the escalator. | CTD | Ⓢ | Ⓢ |
| 09 Drive Chain Safety Device | When the drive chain breaks or extends abnormally, stop the escalator. | DCS | Ⓢ | Ⓢ |
| 10 Cover Plate Safety Device | When the maintenance cover plate is taken out, stop the escalator or prevent it from starting. | DOS | Ⓢ | Ⓢ |
| 11 Emergency Stop Button | In emergency, use this device to stop the escalator. | E-STOP | Ⓢ | Ⓢ |
| 12 Detection of Auxiliary Brake Actions | When the auxiliary brake is not in place, prevent the escalator from starting. (When the rise is above 6m) | EBR ⁻³ | Ⓢ | Ⓢ |
| 13 Electric Safety Circuit Protection | When there is any action in the electric safety devices connected in serial, stop the escalator. | ESC | Ⓢ | Ⓢ |
| 14 Detection of Braking Distance | When the brake distance gets longer than 1.2 times the defined maximum, prevent the escalator from starting. | ESD | Ⓢ | Ⓢ |
| 15 Handrail Anti-static Device | The device prevents static from occurring on the handrail. | HER | Ⓢ | Ⓢ |
| 16 Over-speed | Stop the escalator before the operational velocity grows above 1.2 times the nominal velocity. | HGD1 | Ⓢ | Ⓢ |
| 17 Over-speed Limitation Device | Stop the escalator before the operational velocity grows above 1.4 times the nominal velocity. (when the rise is above 6m) | HGD2 ⁻³ | Ⓢ | Ⓢ |
| 18 Handrail Inlet Safety Device | When any foreign object gets pinched into the handrail inlet, stop the escalator. | HGS | Ⓢ | Ⓢ |
| 19 Handrail Velocity Inspection | When the velocity of the handrail is below the rated value, and the condition lasts for a period of time, stop the escalator. | HSS | Ⓢ | Ⓢ |
| 20 Under-voltage Protection | When the voltage of the frequency converter is too low, stop the escalator. | LVP | — | Ⓢ |
| 21 Over-current Protection | When the electric current of the frequency converter is too strong, stop the escalator. | OCP | — | Ⓢ |
| 22 Motor Overload Protection | When the motor is overloaded, stop the escalator. | OCR | Ⓢ | Ⓢ |
| 23 Over-voltage Protection | When the voltage of the frequency converter is too high, stop the escalator. | OVP | — | Ⓢ |
| 24 Detection of Power Phase | Automatically inspect the power phase and frequency, and switch to bypass frequency converter in a shock-free manner. Realize self-adaptation control of power factors with the full frequency converter. | PLL | — | Ⓢ |
| 25 Error of the Passenger Detection Device | Self-diagnosis of error with the passenger detection device. In case of any error, cancel the standby model. | PSD | — | Ⓢ |
| 26 Step Chain Safety Device | When the step chains break or extend abnormally, stop the escalator. | SCS | Ⓢ | Ⓢ |
| 27 Finch-proof Device at the Skirting | Device with a rigid base installed on the skirting panels, to prevent foreign objects or feet from falling between the skirting panels and the steps. | SDS | Ⓢ | Ⓢ |
| 28 Step Anti-static Device | The device prevents static from occurring on the steps. | SER | Ⓢ | Ⓢ |
| 29 Steps Missing Safety Device | When there is any step missing, the device takes action to stop the escalator. | SMS | Ⓢ | Ⓢ |
| 30 Steps Sinking Safety Device | If any part of a step sinks and the step cannot mesh with the comb plate, stop the escalator. | SRS | Ⓢ | Ⓢ |
| 31 Skirting Panel Safety Device | When any foreign object falls between steps and skirting panels, stop the escalator. | SSS | Ⓢ | Ⓢ |
| 32 Monitoring Cohesion of the Starting Switch | In case of cohesion of the starting switch, prevent the escalator from starting. | SWD | Ⓢ | Ⓢ |
| 33 Overheating Protection of Frequency Converter | When the frequency converter is overheated, stop the escalator. | THMF | — | Ⓢ |
| 34 Low Velocity Protection | When the velocity of the escalator is below the rated velocity, stop the escalator. | USP | Ⓢ | Ⓢ |
| 35 Water Level Warning Device | When too much water is accumulated in the lower truss, stop the escalator. | FLS ⁻⁴ | Ⓢ | Ⓢ |
| 36 Oil Level Warning | When the oil level in the oil feeding device is too low, prevent the escalator from starting. | OILF | Ⓢ | Ⓢ |
| Emergency Operations | | | | |
| A1 Fire Stop | When a signal of fire-fighting action is received, stop the escalator. | FSS | Ⓢ | Ⓢ |
| Operations and Service Functions | | | | |
| B1 Repair | The escalator can be set to the operation under repair model, to make the installation and commissioning convenient. | HAND | Ⓢ | Ⓢ |
| B2 Manually Shut Down Illumination | Open or shut down illumination manually with the switch. (When auxiliary illumination below steps and/or at the handrails is equipped) | LO-M ⁻⁵ | Ⓢ | Ⓢ |
| B3 Automatic Operation | Through the usage of passenger detection devices, the escalator could operate with the nominal speed when there is any passenger, and shift to standby in case of no load. | MDA | — | Ⓢ |
| B4 Operation with Constant Velocity | The escalator keeps at the nominal velocity. | MDC | Ⓢ | — |
| B5 Automatic Oil Feeding | Add lubricating oil to the chains of the escalator at predetermined time automatically. | OIL | Ⓢ | Ⓢ |
| B6 Passenger Detection Device: Microwave but not the Column Pattern | Adopt microwave sensors for the passenger detection device. | PSM ⁻⁶ | — | Ⓢ |
| B7 Passenger Detection Device: Column Pattern | Adopt the photoelectric column for the passenger detection device. | PSP ⁻⁶ | — | Ⓢ |
| B8 Low Velocity Standby | The escalator operates below the nominal velocity in the condition of no load. | SBLS ⁻⁷ | — | Ⓢ |
| B9 Stop Standby | The escalator stops in the condition of no load. | SBSP ⁻⁷ | — | Ⓢ |
| B10 Direct Start-up | Supply power with direct drive with mains at both starting and operation of the escalator, and the frequency converter serves merely as a backup. | SDT ⁻⁸ | Ⓢ | Ⓢ |
| B11 Optional Directions of Operation | The direction of escalator operation could be reversed. | UDA | Ⓢ | Ⓢ |
| B12 Bypass Frequency Converter | Supply power with frequency converter at starting, stop, and low velocity standby, and shift to direct drive with mains during operations with rated velocity. | VFBF | — | Ⓢ |
| B13 Heating Device | Monitor the escalator with temperature sensors in a real-time manner. When the temperature in the escalator is lower than the rated value, prevent the escalator from starting. The device can automatically start or stop heating as per the actual temperature. | HEAT | Ⓢ | Ⓢ |
| Information and Display | | | | |
| C1 Displaying Safety Device Codes | Carry out one-on-one inspection on safety devices, and display response error codes if there is any error. | ASD ⁻⁹ | Ⓢ | Ⓢ |
| C2 BA Interface | Use passive dry contact to output signals indicating basic status of the escalator. | BA | Ⓢ | Ⓢ |
| C3 Buzzer | Remind the passengers of escalator starting, error, reversion, and etc. | BUZ | Ⓢ | Ⓢ |
| C4 Operational Direction Indication | Indicate the passengers the operational direction, stop, no entry, or other conditions of the escalator. | DI ⁻¹⁰ | Ⓢ | Ⓢ |
| C5 Reminder of Fire-protection Stop | When the escalator stops for fire-protection reasons, release the signal of fire-protection stop. | FE-CP | Ⓢ | Ⓢ |
| C6 Handrail Illumination | Illumination at the lower edge of the handrail. | L-BAL ⁻¹¹ | Ⓢ | Ⓢ |
| C7 Illumination Below Steps | Illumination at the inlet and outlet of the staircase, highlighting the edge of the staircase. | L-STP ⁻¹² | Ⓢ | Ⓢ |
| C8 The Monitoring System | The system monitors the status of the escalator with computers, and gives orders of starting or stop when necessary. | SMOS-II | Ⓢ | Ⓢ |
| C9 Skirting Illumination | Illumination on the skirting panels at both sides of the staircase. | L-SKT ⁻¹¹ | Ⓢ | Ⓢ |
| C10 Comb Illumination | Illumination on the skirting panels at the inlet and outlet of the staircase or pallets. | L-COMB ⁻¹² | Ⓢ | Ⓢ |

Note:

- *1 Standard component when the rise is above 6 meters.
- *2 Non-standard component when the rise is 6 meters or below.
- *3 Standard component when auxiliary brakes are equipped.
- *4 Standard component only when the escalator is installed outdoor or half-outdoor.
- *5 When there is illumination system on the escalator.
- *6 PSM or PSP (PSM is the recommended option)
- *7 SBLS or SBSP (SBSP is recommended indoor option)
- *8 The normal start-up model for non-frequency conversion escalators, and backup for frequency conversion escalators.
- *9 Non-standard
- *10 Non-standard for non-frequency conversion escalators
- *11 Only for indoor KS-LB/KS-L BF
- *12 Indoor
- *13 Non-frequency conversion versions: KS-SB, KS-LB, KP-B; frequency conversion versions: KS-SBF, KS-LBF, KP-BF
- *14 Ⓢ Standard functions, Ⓢ optional functions

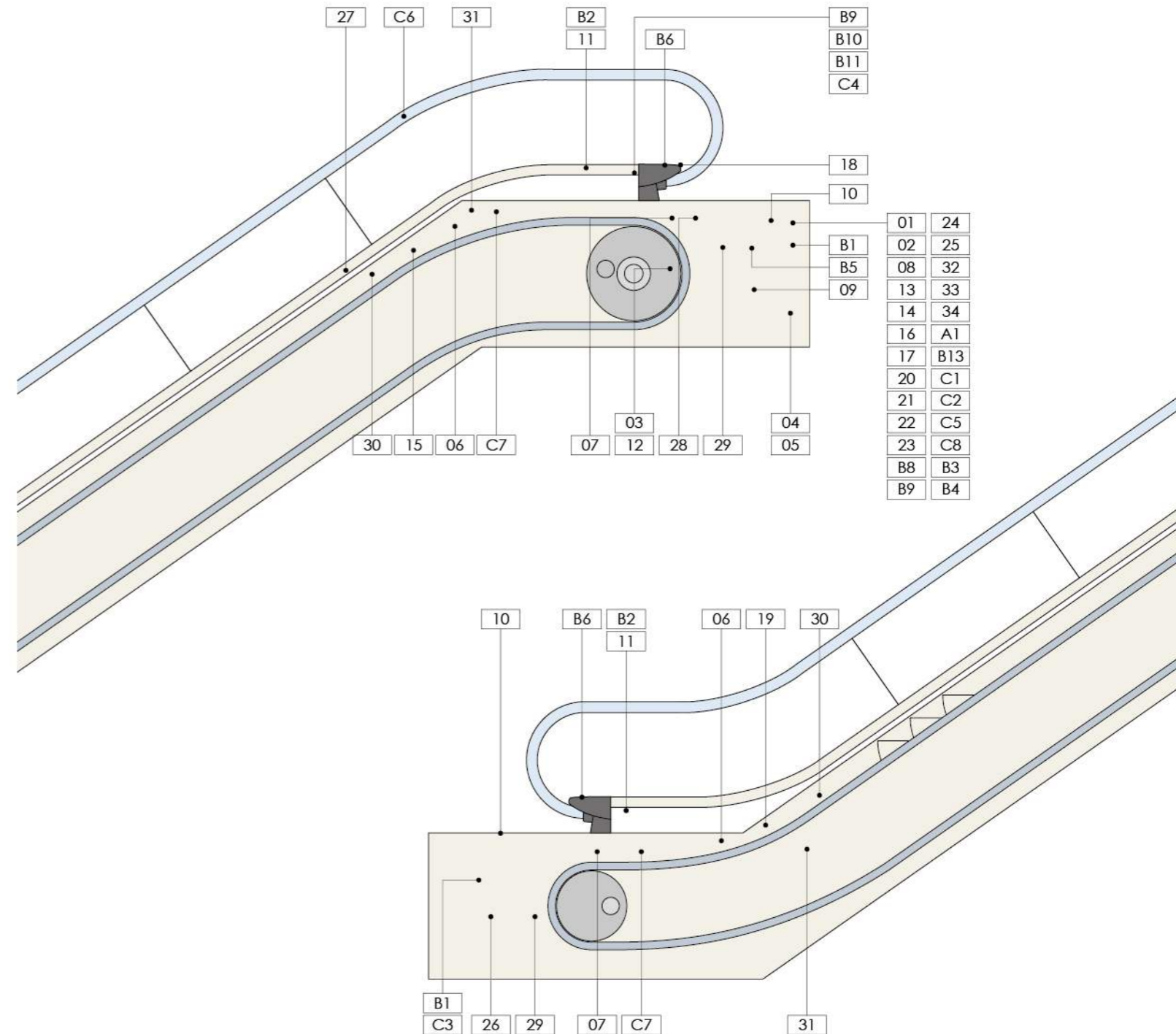

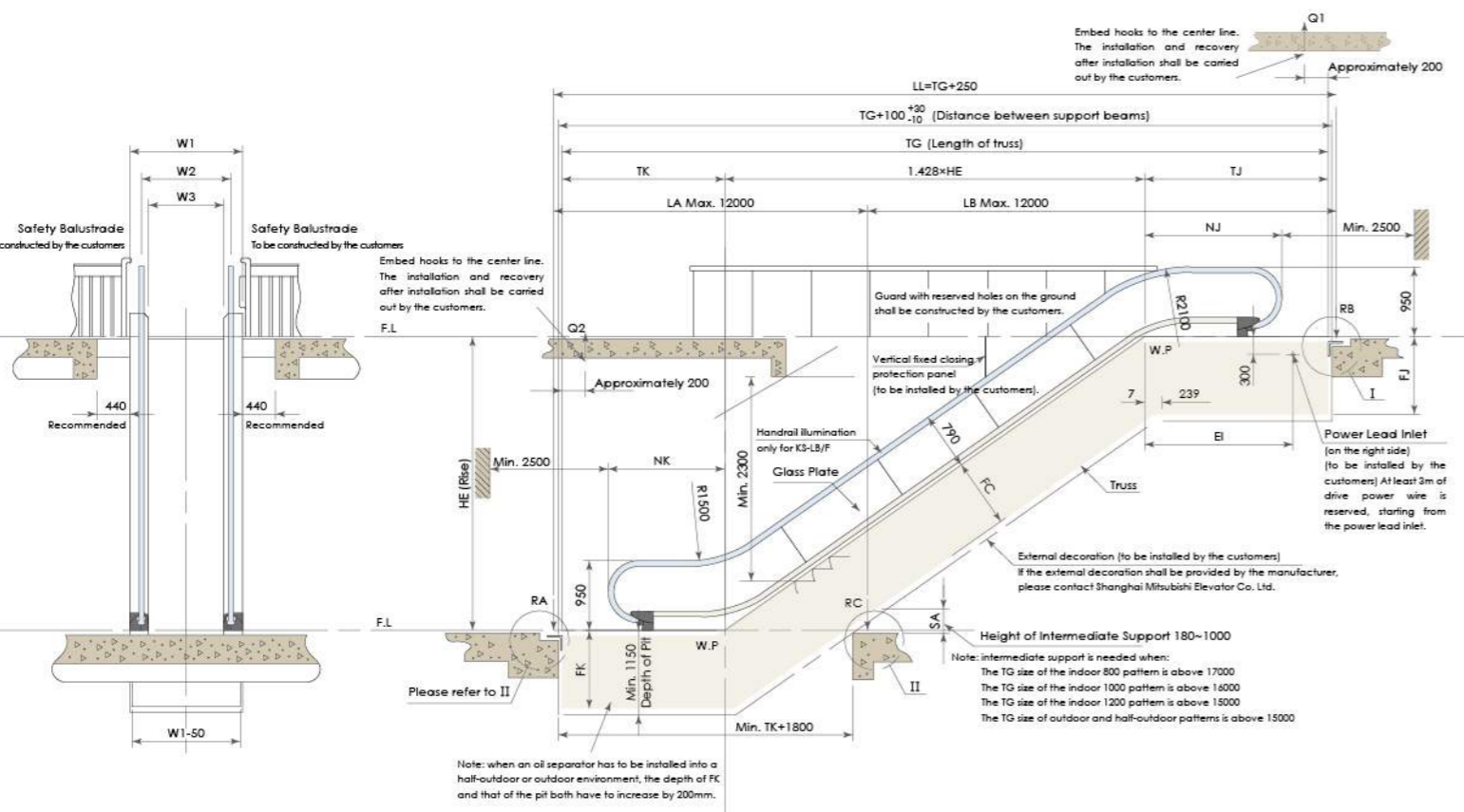

Note:
 1: This drawing carried only basic requirements for indoor environment
 2: As there are different requirements and interfaces in each installation environment, please make sure to contact Shanghai Mitsubishi Elevator Co. Ltd. in the process of operations design.

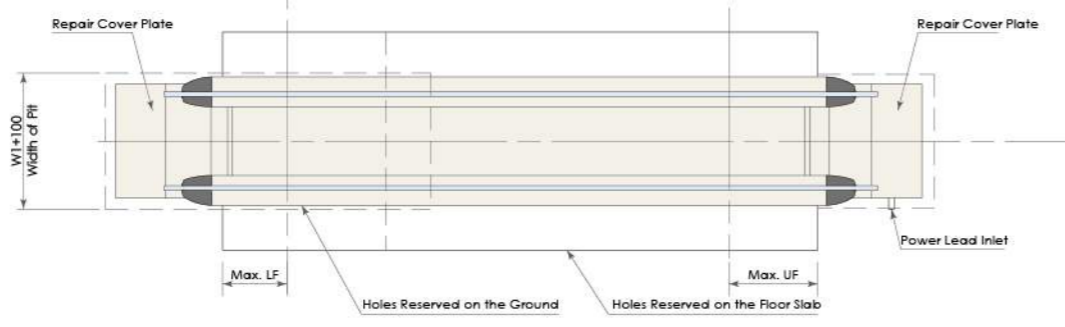

End Support Drawing

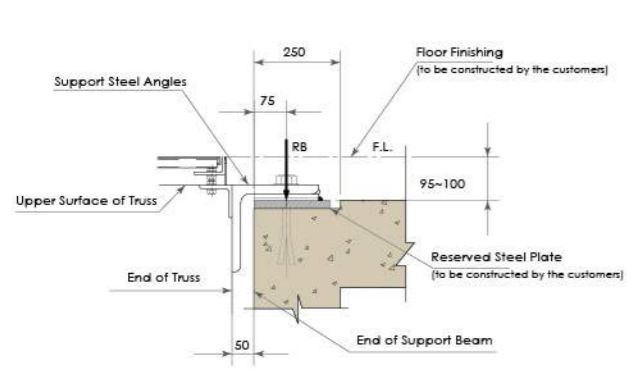

Intermediate Support Drawing

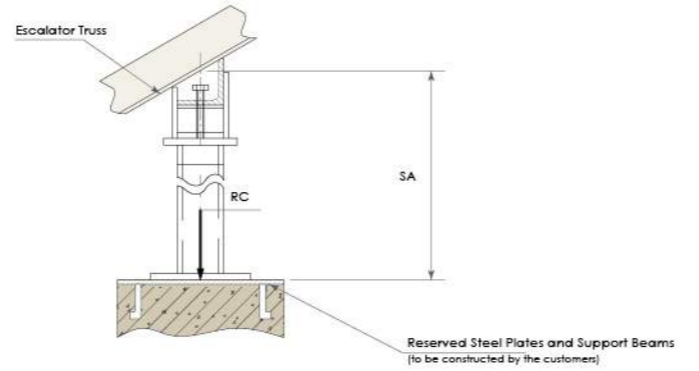

| Item | Standard | Optional | Note |
|---|-----------------|--|--|
| Length of the Upper Truss TJ (mm) | 2437 | 2438-5137 | Rise ≤ 7000mm / Angle of inclination 30° / Level 2 steps / Handrail nominal width 1000 or 1200 |
| | 2937 | 2938-5137 | Rise ≤ 7000mm / Angle of inclination 30° / Level 2 steps / Handrail nominal width 800 |
| | 2842 | 2843-5542 | Rise ≤ 7000mm / Angle of inclination 30° / Level 3 steps / Handrail nominal width 1000 or 1200 |
| | 3342 | 3343-5542 | Rise ≤ 7000mm / Angle of inclination 30° / Level 3 steps / Handrail nominal width 800 |
| | 2497 | 2498-5197 | Angle of inclination 35° / Level 2 steps / Handrail nominal width 1000 or 1200 |
| | 2997 | 2998-5197 | Angle of inclination 35° / Level 2 steps / Handrail nominal width 800 |
| | 2902 | 2903-5602 | Angle of inclination 35° / Level 3 steps / Handrail nominal width 1000 or 1200 |
| | 3402 | 3403-5602 | Angle of inclination 35° / Level 3 steps / Handrail nominal width 800 |
| | 3142 | 3143-5542 | 7000mm < Rise ≤ 10000mm / angle of inclination 30° / Handrail nominal width 1200 |
| | 2842 | 2843-5542 | 7000mm < Rise ≤ 8500mm / Angle of inclination 30° / Handrail nominal width 1000 |
| 3142 | 3143-5542 | 8500mm < Rise ≤ 10000mm / Angle of inclination 30° / Handrail nominal width 1000 | |
| 3642 | 3643-5542 | 7000mm < Rise ≤ 10000mm / Angle of inclination 30° / Handrail nominal width 800 | |
| Length of the Lower Truss TK (mm) | 2180 | 2181-4880 | Angle of inclination 30° / Level 2 steps |
| | 2585 | 2586-5285 | Angle of inclination 30° / Level 3 steps |
| | 2215 | 2216-4915 | Angle of inclination 35° / Level 2 steps |
| | 2620 | 2621-5320 | Angle of inclination 35° / Level 3 steps |
| Depth of the Upper Truss FJ (mm) | 1060 | | |
| | 1060 | | |
| Depth of the Lower Truss FK (mm) | 1060 | | |
| | 1060 | | |
| Depth of the Middle Truss FC (mm) | 918 | | Angle of inclination 30° |
| | 938 | | Angle of inclination 35° |
| Width of the Escalator W1 (mm) | 1550 | | Handrail nominal width 1200 |
| | 1350 | | Handrail nominal width 1000 |
| | 1150 | | Handrail nominal width 800 |
| Distance Between Intermediate Supports LA | (TK+250) ~12000 | | 1 or 2 intermediate supports, angle of inclination 30°, (LA) between (TK+250) and 12000 |
| | (TK+370) ~12000 | | 1 or 2 intermediate supports, angle of inclination 35°, (LA) between (TK+370) and 12000 |
| Distance Between Intermediate Supports LB | (TJ+240) ~12000 | | 1 or 2 intermediate supports, angle of inclination 30°, (LB) between (TJ+240) and 12000 |
| | (TJ+110) ~12000 | | 1 or 2 intermediate supports, angle of inclination 35°, (LB) between (TJ+110) and 12000 |
| Distance Between Intermediate Supports LC | 500~12000 | | 2 or more intermediate supports |



Basic Specifications

| Item | Specification | | | Note |
|---|--|------|------|---|
| Nominal Width Between Handrails (mm) | 1200 | 1000 | 800 | |
| Distance Between Center Lines of Handrails (mm) | 1228 | 1028 | 828 | |
| Nominal Width of Steps (mm) | 1004 | 804 | 604 | |
| Maximum Load (Person/Hour) | 6000 | 4800 | 3600 | |
| Serial No. | KS-SB/KS-SBF, KS-LB/KS-LBF, KP-B/KP-BF | | | KS-LB/KS-LBF cannot be applied to outdoor or half-outdoor environment |
| Drive System | Direct Drive | | | KS-SB, KS-LB, KP-B |
| | VVVF Drive | | | KS-SBF, KS-LBF, KP-BF |
| Drive Power Supply | 380V50Hz three-phase and five-wire | | | |
| Illumination Power Supply | 220V50Hz single phase | | | |
| Angle of Inclination (Degree) | 30, 35 | | | |
| Velocity (m/s) | 0.5 | | | |
| Escalator Rise (mm) | 1400~10000 | | | When the angle of inclination is 30° |
| | 1606~6000 | | | When the angle of inclination is 35° |
| Horizontal Movement Distance of Steps (mm) | 800 | | | Level 2 steps, Rise ≤ 6000mm. |
| | 1200 | | | Level 3 steps, Rise ≤ 6000mm. |
| | 1200 | | | Level 3 steps, Rise > 6000mm. |
| Applicable Environment | Indoor | | | Please contact the Shanghai Mitsubishi Elevator Co. Ltd. to confirm if the escalator could be used indoor. |
| | Outdoor, half-outdoor | | | Please contact the Shanghai Mitsubishi Elevator Co. Ltd. to confirm if the escalator could be used outdoor and/or half-outdoor. |

Power Supply Data

Driving Power (three phase AC 380V, 50Hz)

| | | |
|------------------------------|---|--|
| Driving Power Capacity (kVA) | 8.0 | The motor power capacity is 5.5kW, without heater. |
| | 10.4 | The motor power capacity is 7.5kW, without heater. |
| | 13.2 | The motor power capacity is 9kW, without heater. |
| | 15.4 | The motor power capacity is 11kW, without heater. |
| | 18.0 | The motor power capacity is 13kW, without heater. |
| | 10 | Heater at 30 degrees, Rise ≤ 3500mm. |
| | 13 | Heater at 30 degrees, 3500mm < Rise ≤ 5300mm. |
| | 16 | Heater at 30 degrees, 5300mm < Rise ≤ 8300mm. |
| | 19 | Heater at 30 degrees, 8300mm < Rise ≤ 10000mm. |
| | 10 | Heater at 35 degrees, Rise ≤ 4000mm. |
| 13 | Heater at 35 degrees, 4000mm < Rise ≤ 6000mm. | |

Illumination Power (single phase AC 220V, 50Hz)

| Serial No. | KS-LB/KS-LBF | KP-B/KP-BF | KS-SB/KS-SBF | Note |
|-----------------------------------|--------------|------------|--------------|---|
| Illumination Power Capacity (kVA) | 2.2 | 2.2 | 2.2 | Rise ≤ 6000mm, with handrail or skirting illumination. |
| | 2.6 | 2.6 | 2.6 | 6000mm < Rise ≤ 10000mm, with handrail or skirting illumination |
| | — | 1.3 | 1.3 | No handrail or skirting illumination |

Motor Capacity

| | | | | |
|-----------------------------|------|------|-----|-------------------------|
| Handrail Nominal Width (mm) | 1200 | 1000 | 800 | |
| Motor Capacity (kW) | 5.5 | 5.5 | 5.5 | Rise ≤ 4000mm |
| | 7.5 | 5.5 | 5.5 | 4000mm < Rise ≤ 5000mm |
| | 7.5 | 7.5 | 5.5 | 5000mm < Rise ≤ 6000mm |
| | 9 | 7.5 | 5.5 | 6000mm < Rise ≤ 7000mm |
| | 11 | 9 | 7.5 | 7000mm < Rise ≤ 8500mm |
| | 13 | 11 | 7.5 | 8500mm < Rise ≤ 10000mm |

Note: if the items do not match with the standards provided here, please contact the Shanghai Mitsubishi Elevator Co. Ltd.



**Sense of Secure and Peace
to Create Harmonious Space of Life**

Technology Improves Life

Science Guides the Smart Future

Shanghai Mitsubishi Elevator stays beside you

